

# FEMC®

INNOVATIVE  
PACKAGING MACHINERY

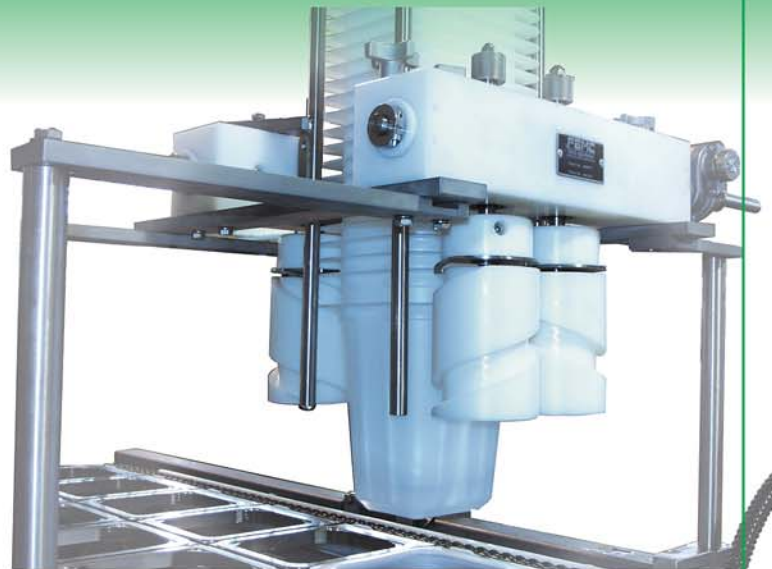

## UNIVERSAL SCREW DENESTER

High-speed container placement

Designed to automatically denest and accurately place trays, lids, cups or any items that possess uniform stacking features.

Every Universal Screw Denester is adjustable for any size container without the need for tools, and can reach speeds of 300 containers per minute in a single lane!

Available in standalone or line-mounted configurations for maximum flexibility and ease of integration.



FEMC Standalone Servo-driven  
Universal Screw Denester



## KEY BENEFITS

- Accurate, positive and adjustable container placement
- Rugged and reliable
- Easy to operate and maintain
- "Tool-less" 5-minute container changeover



# FEMC Universal Screw Denester

The patented FEMC Universal Screw Denester is capable of placing containers that are uniform in size, semi-rigid and have an equal amount of space between the flanges when stacked. Most plastic and many aluminum containers are ideal for denesting by the Universal Screw Denester. FEMC's innovative screw design, first separates each container from the stack with a stainless steel denesting blade. The container is then further separated from the stack thanks to a longer, secondary screw; breaking the vacuum formed between container and stack. This helps to ensure accurate and error-free placement.

- Hardcoated aluminum frame
- 24" Stainless Steel stacking rods
- Precision machined 6061 aluminum gearboxes
- Four Delrin denesting screws with stainless steel blades
- Designed to withstand water washdown
- USDA and/or 3-A Sanitary (dairy) approved

## Options and accessories

Angular stacking rods .....Accommodates larger number of containers  
 Type 314/314L Stainless Steel construction .....For dairy and high acidity applications  
 Independent variable speed drive .....Adds mobility and versatility to your standalone unit  
 Multiple lanes .....Accommodates higher production speeds  
 Large aperture .....For containers larger than 10" (parallel to direction of travel)  
 No container/No place option .....For lids and/or accessory items placed by the denester  
 Independent frame .....Adds mobility and versatility to your denester  
 Automatic tray loader .....Places stacks of containers into magazine without user intervention

## Specifications

**Model No:** .....1020  
**Speed:** .....300 CPM (max)  
**Approximate Weight:** .....75 lbs.  
**Changeover Time:** .....approximately 5 mins

**Requirements:** (electrical) ..... 120V/220V/480V (standalone only)  
 (air) ..... N/A

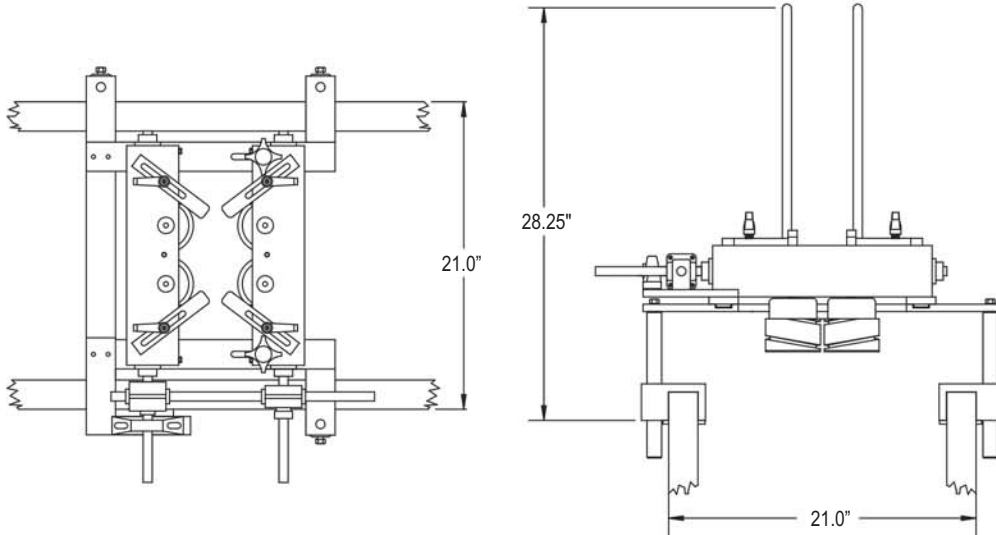

## Proven products and applications



... and more!

**FEMC**<sup>®</sup>  
 INNOVATIVE  
 PACKAGING MACHINERY

22201 Aurora Road  
 Bedford Heights, Ohio 44146

Tel: (216) 663-1208  
 Fax: (216) 663-9337  
 Website: www.femc.com